

# Fluid Energy Jet Mill/ Current Jet

# CURRENT JET

## Applications

**A simple system for fine particle pulverizing.**

**Wide range of applications.**

Particles are pulverized solely on the principle of air pressure, avoiding the use of moving parts and the resulting heat and particle contamination.

### Organic Chemical Industry

*Toner,  
Powder Paints,  
Plastics,  
Pharmaceuticals,  
Other Powders*

### Minerals

*Coal,  
Calcium Carbonate,  
Cement,  
Mica,  
Silica Sand,  
Tourmaline,  
etc..*

### Inorganic Chemical Industry

*Carbon,  
Graphite,  
Paints,  
Ceramics,  
Glass,  
Silk,  
etc..*

### Metals

*Silver,  
Nickel,  
Copper,  
Iron Oxide,  
Magnesium Oxide  
etc..*

## Pulverizing Mechanism

**Compressed air is used to collide and crush the particles at high speeds.**

The suction of the injector guides the dispersed particles into the pulverizing zone. The continuous high speed collisions caused by the compressed air crushes the particles. The particles then pass through the classifying zone, and are discharged from the machine with the compressed air.

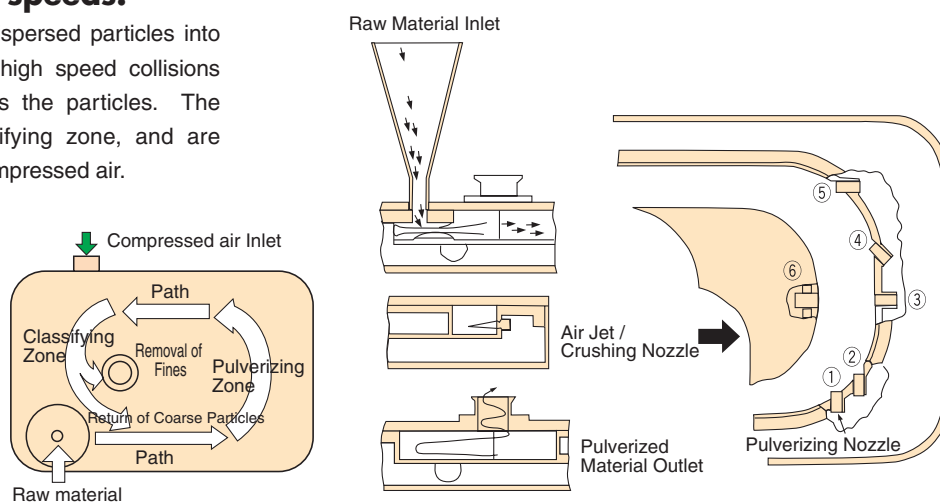

**The Current Jet, high-performance pulverizing combined with ease of operation.**

**The scalability of this series of machines maintains pulverized particle sizes even as the size of the machine is increased.**

The Current Jet minimizes mixing of different particle sizes and produces minimal heat by using the air pressure to crush. The unique features of this machine, whether it be low-heat resistant pharmaceuticals, resins with low-melting points, or new materials used in the manufacture of powders for the high tech field, allow the Current Jet to perform high-precision pulverizing.

## Features

### ●Creation of an efficient crushing zone.

Pulverizing nozzles are attached to opposing nozzles already in place and in addition, the pulverizing zone is set to crush particles of a large size, insuring efficient particle crushing.

### ●Classifying mechanism creates consistency in particle size.

The pulverizing and classifying zones are separated, resulting in stable grading and consistency in particle size despite an increase in the feed rate.

### ●The pulverizing nozzle can be set depending upon application

The appropriate pulverizing nozzle can be attached to match the purpose of the crushing. Opposing nozzles make it possible to dam up the air stream locally, in order to extend the time powder particles remain in the pulverizing zone, and thus to improve pulverizing. In addition, over-pulverizing can be avoided by regulating the number of nozzles.

### ●Abrasion and Contamination resistant

All areas that come into contact with powder are coated with a ceramics(SiAlON), which exhibits superior abrasion resistance when compared to ordinary abrasion-resistant coatings. No metal parts are exposed to the area where powder comes into contact, thus avoiding metal contamination.

### ●Only one compressed air inlet

The compressed air inlet has been concentrated in one place, increasing the ease of set-up.

### ●Ease of Operation and Maintenance

The simplicity of design allows for ease of disassembly and maintenance. Ease of operation is also assured. Standardized parts are used, with the advantage that these parts can be substituted for quite easily.

### ●Proprietary Scale Up Method

Complete adjustability of grain-size is achieved by a scale up procedure which maintains the grade of grain size for the standard machine.

**CJ-25 Relationship between particle size and capacity (sample : graphite)**

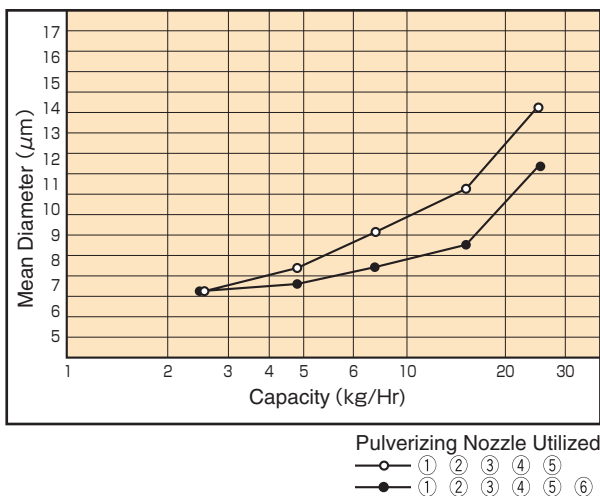

**Required Space**

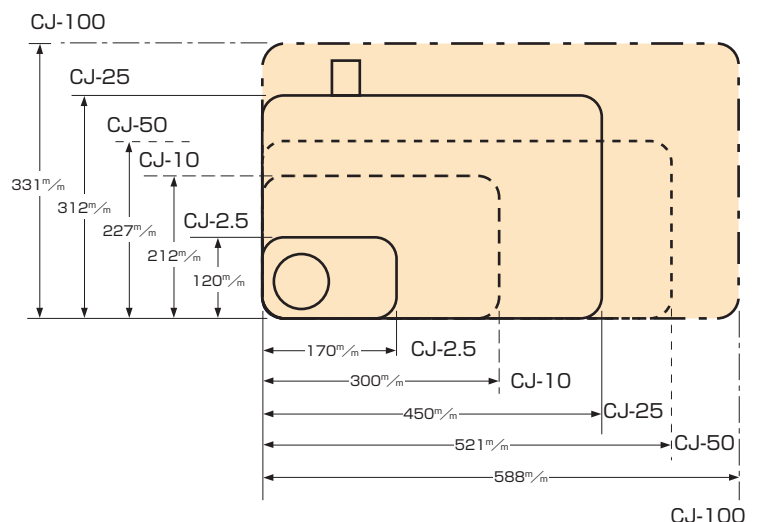

# CURRENT JET

## Pulverizing System Flow

**Pulverized powder is separated from the air and collected.**

The raw material supply is absorbed into the hopper and injected into the mill. The pulverized powder is discharged from the machine with air, and the cyclone and bag filter separate the air from the powder and collect the powder.

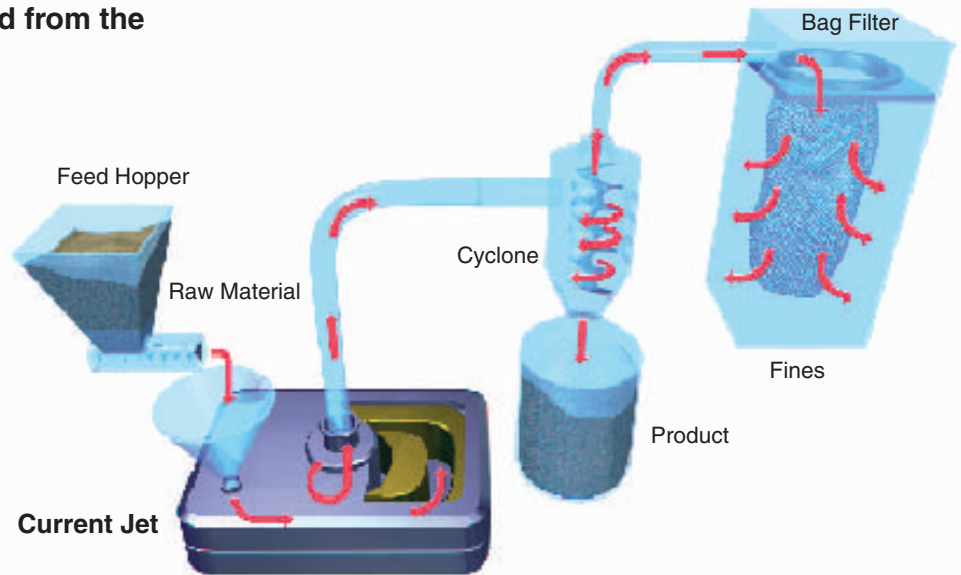

## Examples

**Particle size is controlled by air pressure and feed rate**

The particle size of the pulverized powder can be managed by controlling the air pressure of the air injected into the mill and by controlling the feed rate of the raw material.

Raw Material	Model	Throughput (kg/h)	Raw Material Size		Product Size	
			D <sub>50</sub> (μm)	D <sub>100</sub> (μm)	D <sub>50</sub> (μm)	D <sub>100</sub> (μm)
Carbon	CJ-10	1.0	155	704	3.2	7.8
Glass	CJ-10CB	3.0	—	1000	10.0	350
Calcium Carbonate	CJ-25	10	—	1000	7.1	74.0
Organic Chemicals	CJ-50	60	22.6	148	8.0	62.2
Phenol Resin	CJ-75	27	25.1	74.0	5.6	14.9
Acrylic Powder Paints	CJ-10+TC-15	2.0	—	2000	17.6	32.0
Glass	CJ-50+TC40	15	14.3	248	9.1	44.0

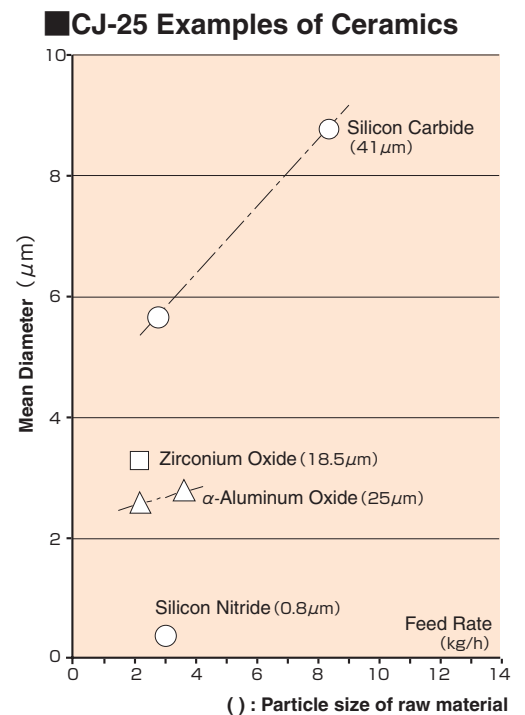
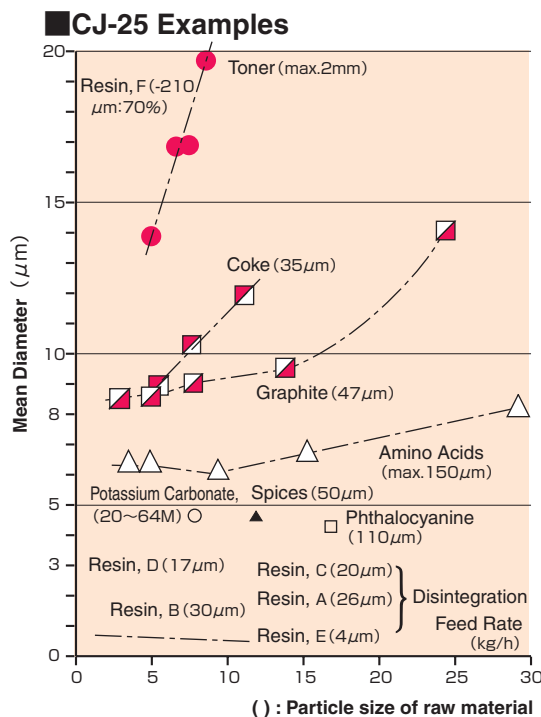

# Fluid Energy Jet Mill / Current Jet

## Integrated System



Turbo Classifier TC-15/Current Jet CJ-10  
(Laboratory use closed pulverizing and classifying system)

**Direct coupling with the Turbo Classifier makes high-precision pulverizing and classifying possible.**

### <Flow sheet>

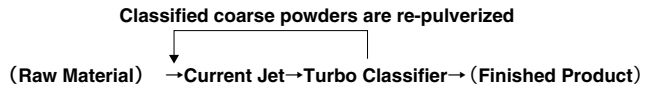

Turbo Classifier TC-15/Current Jet CJ-10  
(Laboratory use closed pulverizing and classifying system)

A combined pulverizing and classifying system made of a Turbo Classifier and a Current Jet.

Pulverizing and classifying performed simultaneously. When the mill is connected directly to the top of the classifier, the powder won't re-agglomerate, and efficient classification can be achieved. Moreover, in a closed system (see left photo) the coarse particles that have been classified are returned to the crushing zone, and particles several mm's in size can be pulverized efficiently to the single micron size range. Space necessary for set-up is very minimal. The CJ-10 can pulverize to the sub-micron size range for the TC-15 classifier. The CJ-25 has additional processing capability and can connect directly to the TC-25. If the CJ-25 and TC-25 are combined, a laboratory particle fineness of 0.8 microns can be achieved. Maximum throughput of 50kg/hr. As for CJ-50-CJ100, TC-40-60 can be combined.

## Specifications

### ●CJ-2.5



### ●CJ-25



### ●CJ-75



### ●CJ-100



Model	Throughput Ratio	Air Volume (m <sup>3</sup> /min)	Compressor (kw)	Dimensions W×D×H (mm)
CJ-2.5	0.1	~0.2	1.5	80×120×170
CJ-10	0.4	~0.8	7.5	300×212×218~270 (Laboratory unit 1000×910×1380)
CJ-25	1	~2.0	15	450×312×343
CJ-50	2	~3.7	22	521×227×759
CJ-75	3	~5.1	45	550×300×760
CJ-100	4	~7.0	55	588×331×789